



Virtual Hardware In the Loop (vHIL) for Accelerating xEV Application Software Development

Dr. Marko Gecic, Infineon Technologies AG

Dineshkumar Selvaraj, Infineon Technologies India

Kevin Brand, Synopsys Australia Pty Ltd



Agenda

1

Objectives

2

AURIX™ TC4x Virtual Prototype

3

AURIX™ TC4x Virtual Motor Control Application Kit

4

Summary

Agenda

1

Objectives

2

AURIX™ TC4x Virtual Prototype

3

AURIX™ TC4x Virtual Motor Control Application Kit

4

Summary

Objectives

- › To start early pre-silicon software development with complete debug and trace toolset support
- › To validate inverter use case (with a focus on motor control) on AURIX™ TC4x microcontroller even before silicon is available
- › To prepare software development kit (SDK) which will be used to control real motor
- › To test algorithm behavior in corner cases without using real hardware

Objectives

AURIX™ TC4x microcontroller architecture

Performance ASIL-D
Enhanced TriCore™
 With up to 6 CPUs @
500MHz

Bigger Tightly Coupled SRAM for increased performance

Full AB-Swap Support

Debug and Trace
 Safe and the secure in field

xSPI
 External Memory Interface

ADC
 Dedicated DSPs
 Enhanced ADCs

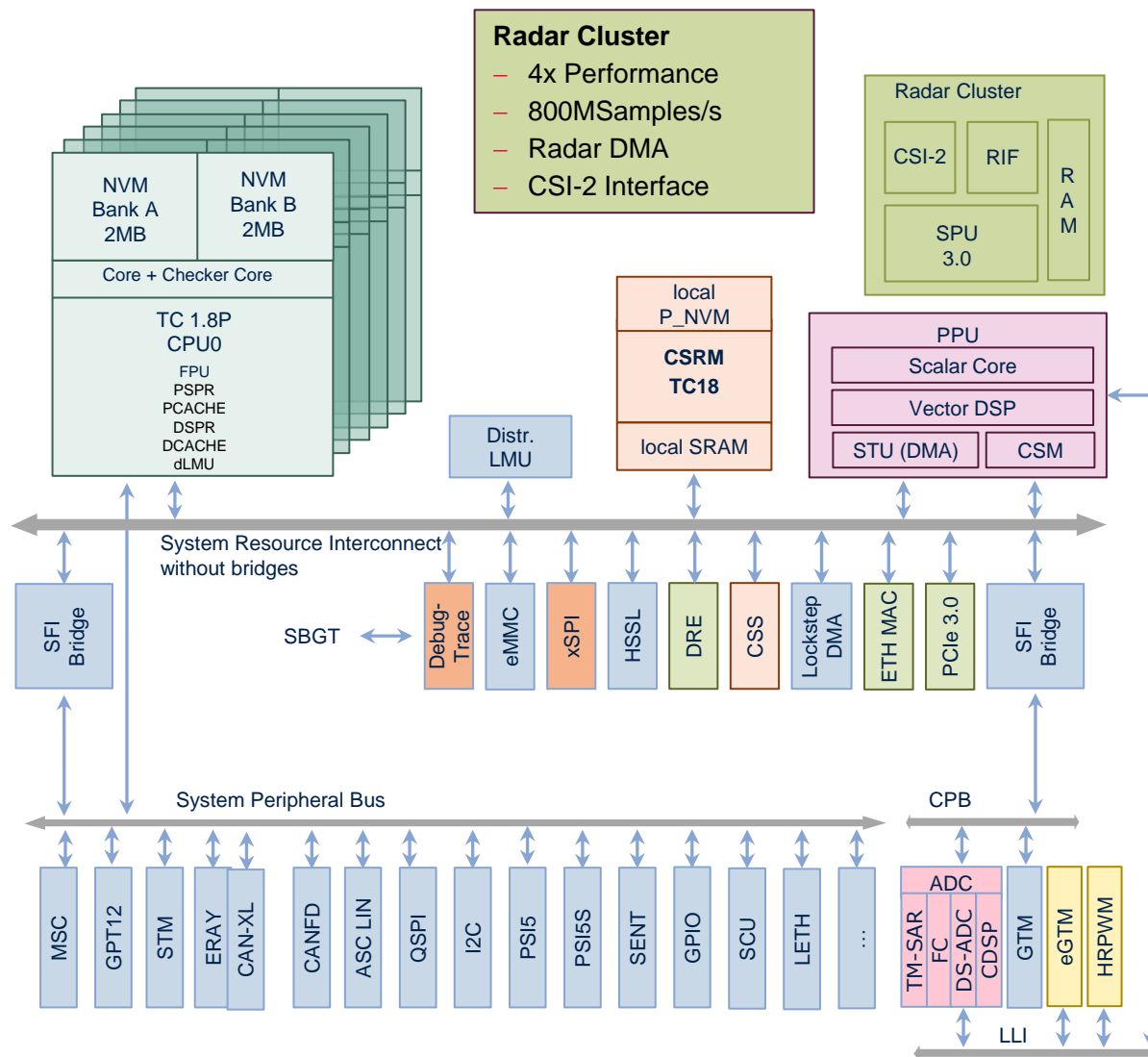

CSR
 New high performance Security Modules with QM support

CSS
 Dedicated communication security satellites

New Programmable HW Accelerator - PPU
SIMD Vector DSP + Scalar Core for Modelling and Precise Control – **ASIL D**

New high-speed comm Interfaces:

- PCIe 3.0
- 100Mb- 5 Gbps Ethernet

New 10 Mbit Ethernet and CAN-XL

New communication routing accelerator:

- DRE- Data Routing Engine

New eGTM timers and High Resolution PWM with low latency interconnect (LLI)

Agenda

1

Objectives

2

AURIX™ TC4x Virtual Prototype

3

AURIX™ TC4x Virtual Motor Control Application Kit

4

Summary

Increasing SW Complexity requires simulation based validation to reduce time and effort

Increased Software Complexity

Tomorrow's Vehicle
6X more lines of code

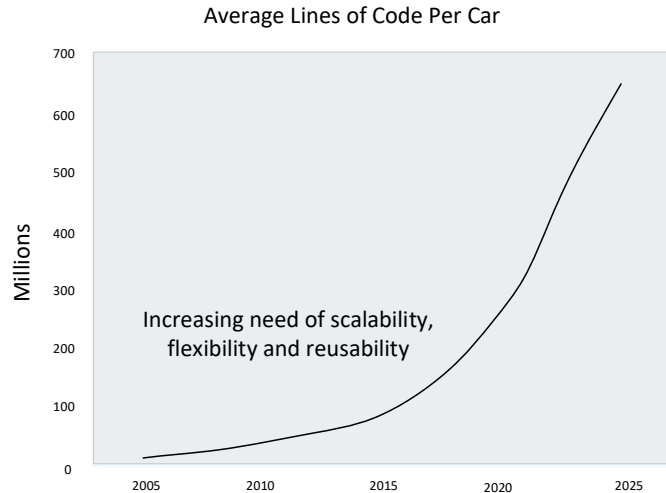

Simulation and Virtual Testing



Benefits

- ✓ Time to Market
- ✓ Cost saving
- ✓ Improved Quality and Safety

What is Virtual Prototype (VP) ?

A simulation platform of HW that can execute target SW applications without any modifications

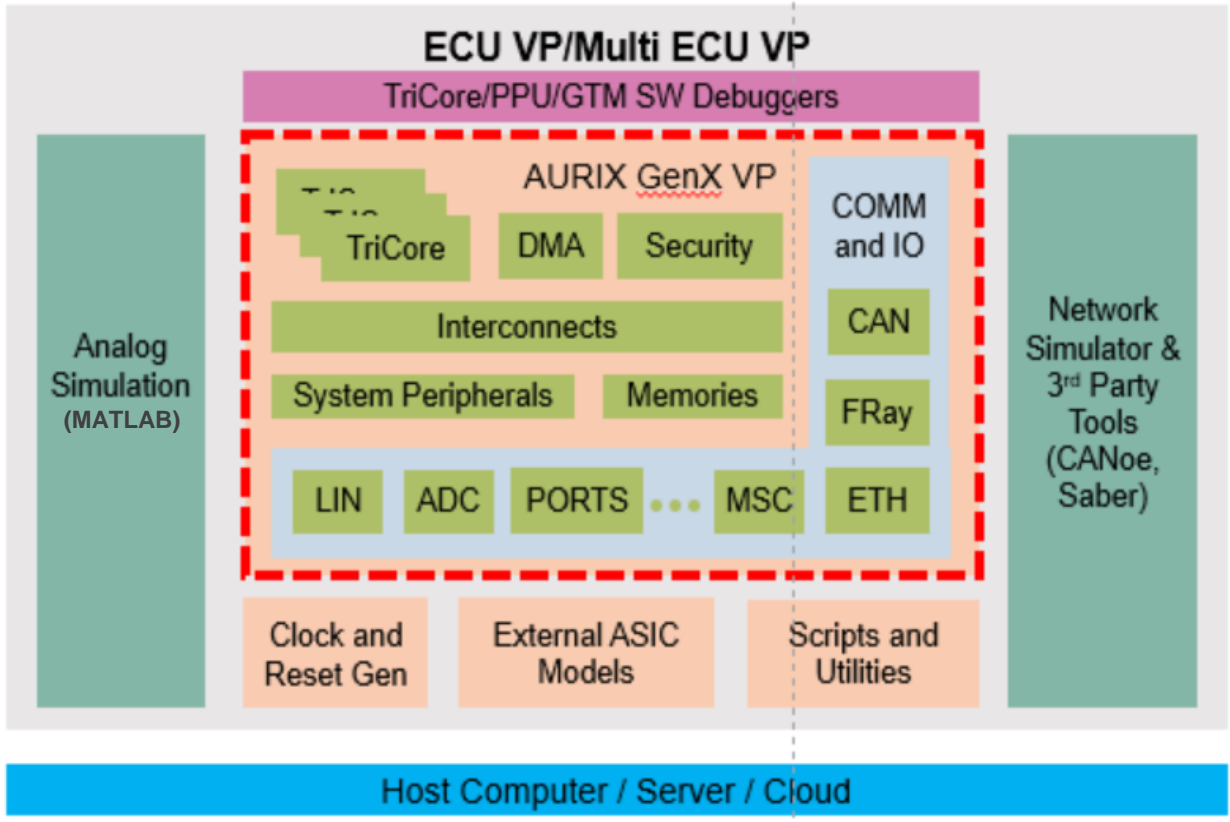
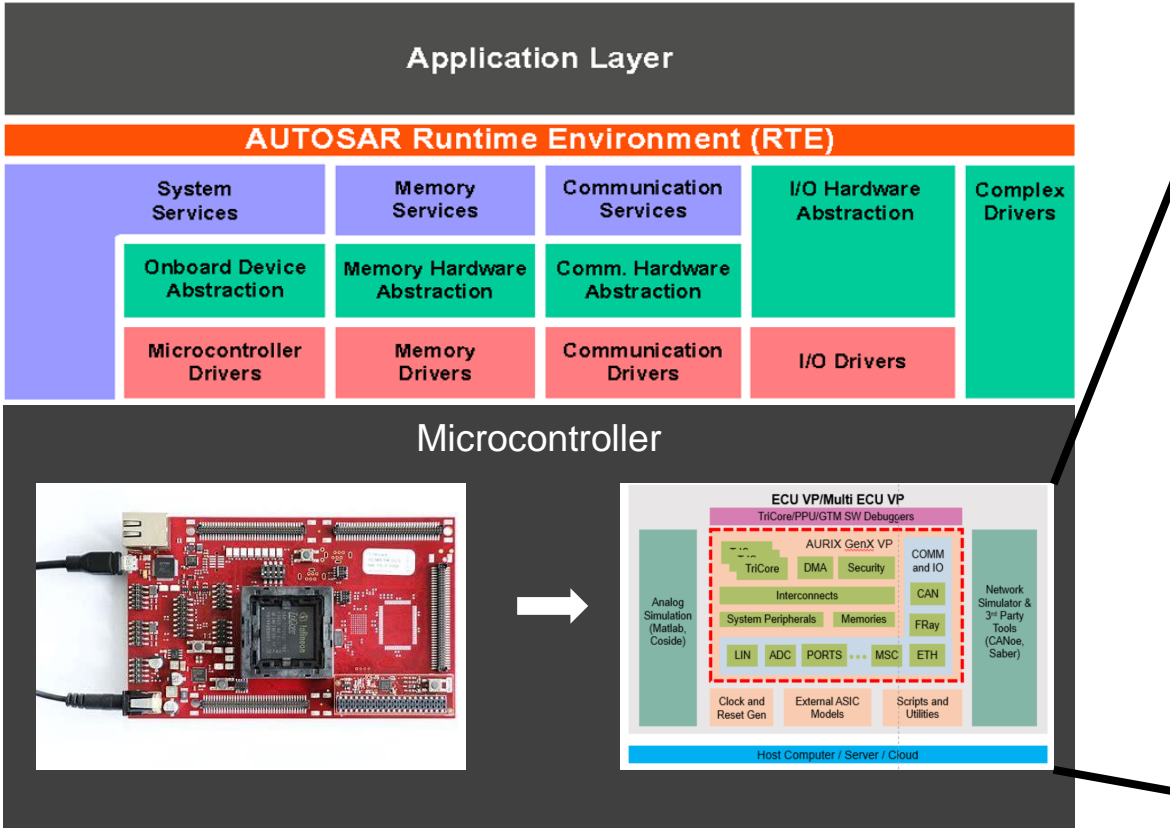

Successful collaboration between Infineon and Synopsys enabling Virtual Prototype across AURIX™ generations



- › Long collaboration over 15 years
 - VP tools and integration
 - IP modelling
 - VP deployment and support
- › Long term partnership for developing Fast Timed Model for TriCore™
 - Reuse of Register-Transfer Level (RTL) tests improves model quality and accuracy
- › Successful deployment into many Tier1 and OEM projects
- › Deepened partnership for AURIX™ TC4x VP via Centre of Excellence (CoE) setup

Synopsys Expands Center of Excellence with Infineon to Deliver Virtualizer Development Kit for AURIX TC4x Automotive Microcontroller

Collaboration for Third Generation Builds on Successful Deployment of VDKs for AURIX TC2x and TC3x Series to Enable Early Software Development at Tier1 and OEM Customers

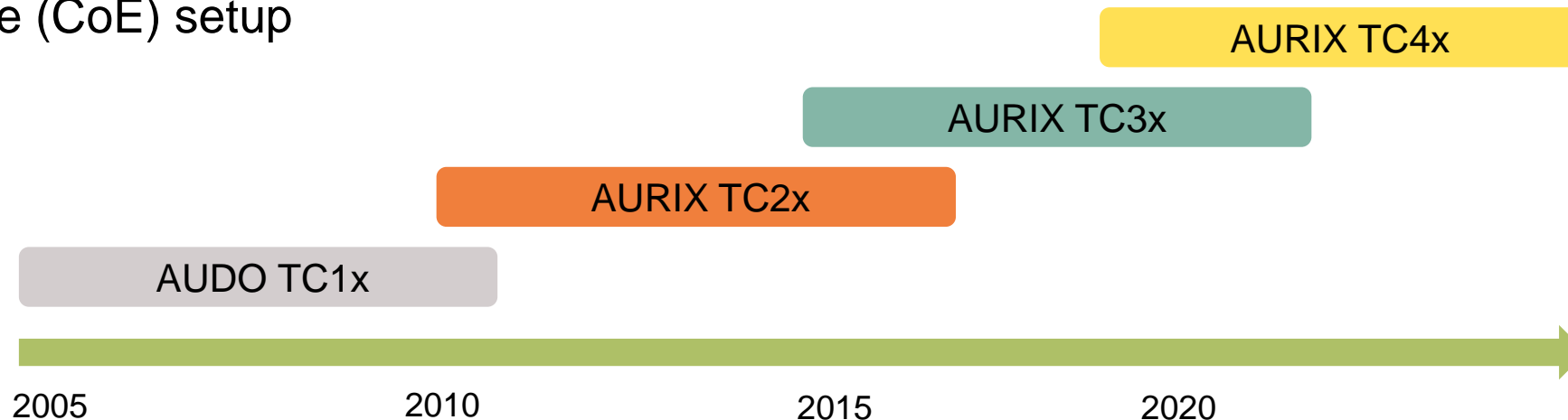

AURIX™ TC4x Virtual Prototype Model-Based Design Flow

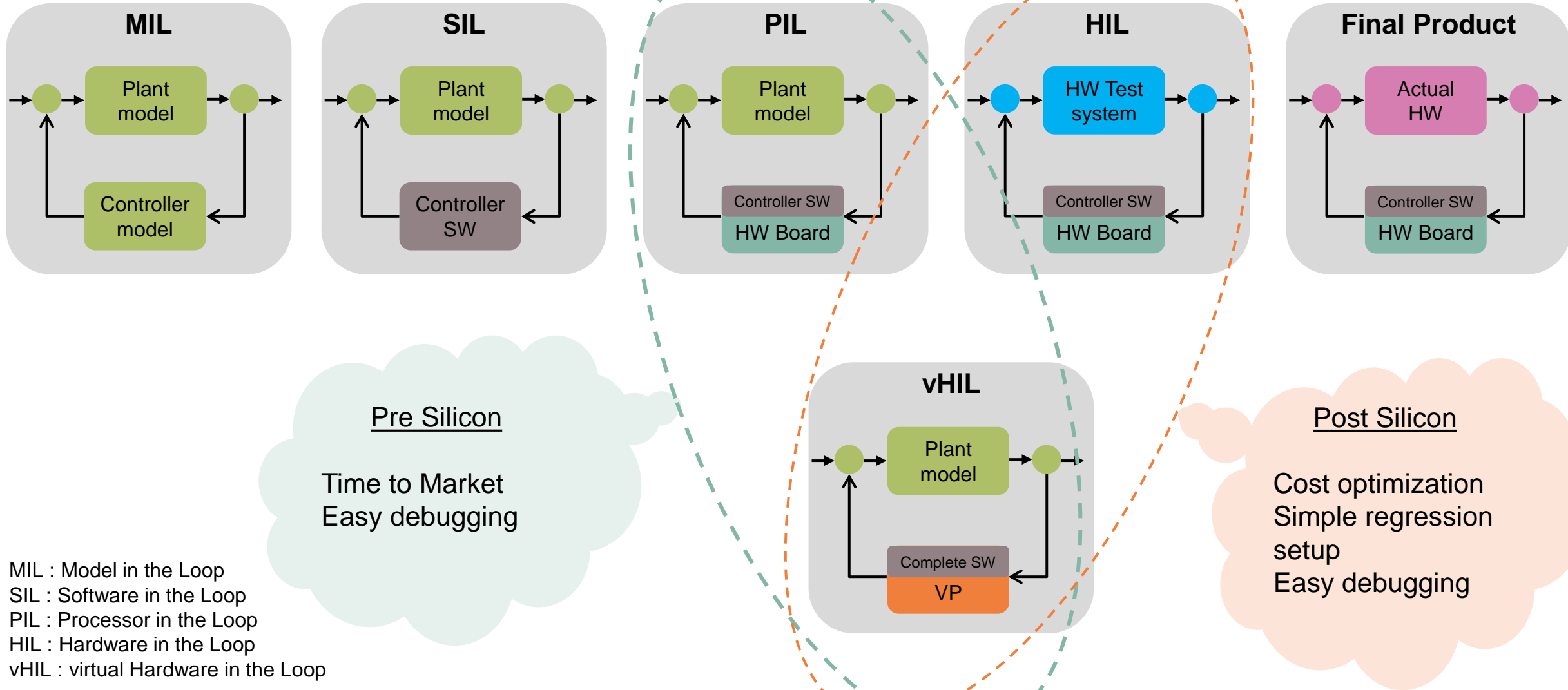

MIL : Model in the Loop
 SIL : Software in the Loop
 PIL : Processor in the Loop
 HIL : Hardware in the Loop
 vHIL : virtual Hardware in the Loop

Agenda

1

Objectives

2

AURIX™ TC4x Virtual Prototype

3

AURIX™ TC4x Virtual Motor Control Application Kit

4

Summary

AURIX™ TC4x Virtual Motor Control Application Kit Development Environment for fast prototyping

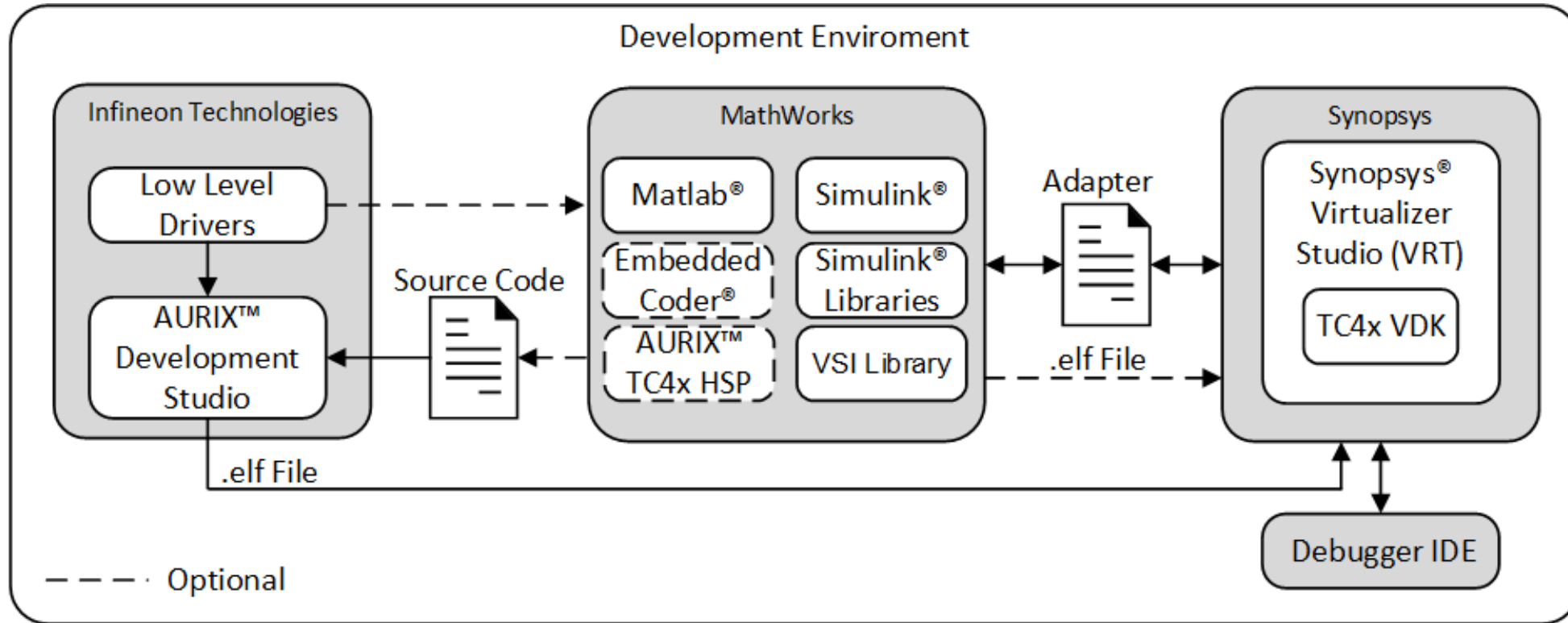

[AURIX™ TC4x HSP](#) – Embedded coder support package for Infineon Technologies AURIX™ TC4x microcontroller

VSI Library - Virtualizer System Interface is a MATLAB®/Simulink® and Synopsys® VDK library, developed by Synopsys® for better co-simulation

Adapter – The adapter is an environment which gives an interface between different simulation environment. Developed using Python

AURIX™ TC4x Virtual Motor Control Application Kit Software Development Kit

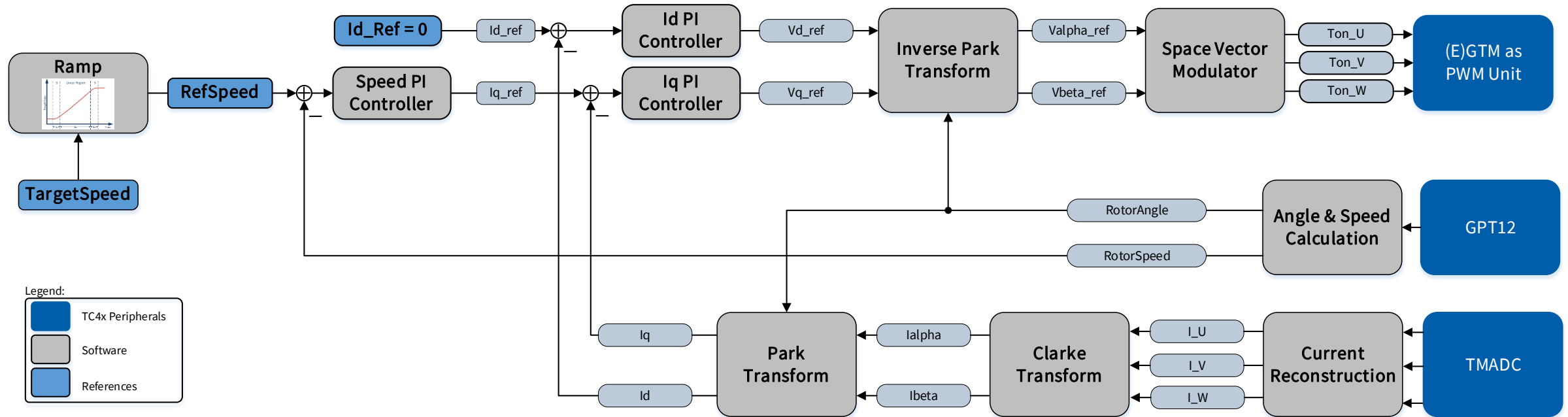

- > Field Oriented Control (FOC) of Permanent Magnet Synchronous Motor (PMSM)
- > Layered approach
- > Infineon Low Level Drivers (iLLD)
- > AURIX™ Development Studio

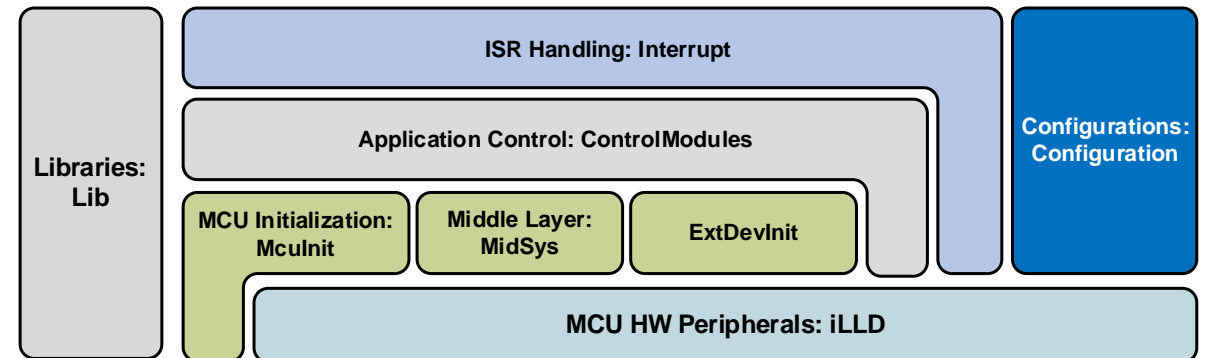

Permanent Magnet Synchronous Motor Field Oriented Control in SI units

Note: This example requires a Infineon AURIX TC4xx Virtual Motor Control Application Kit setup

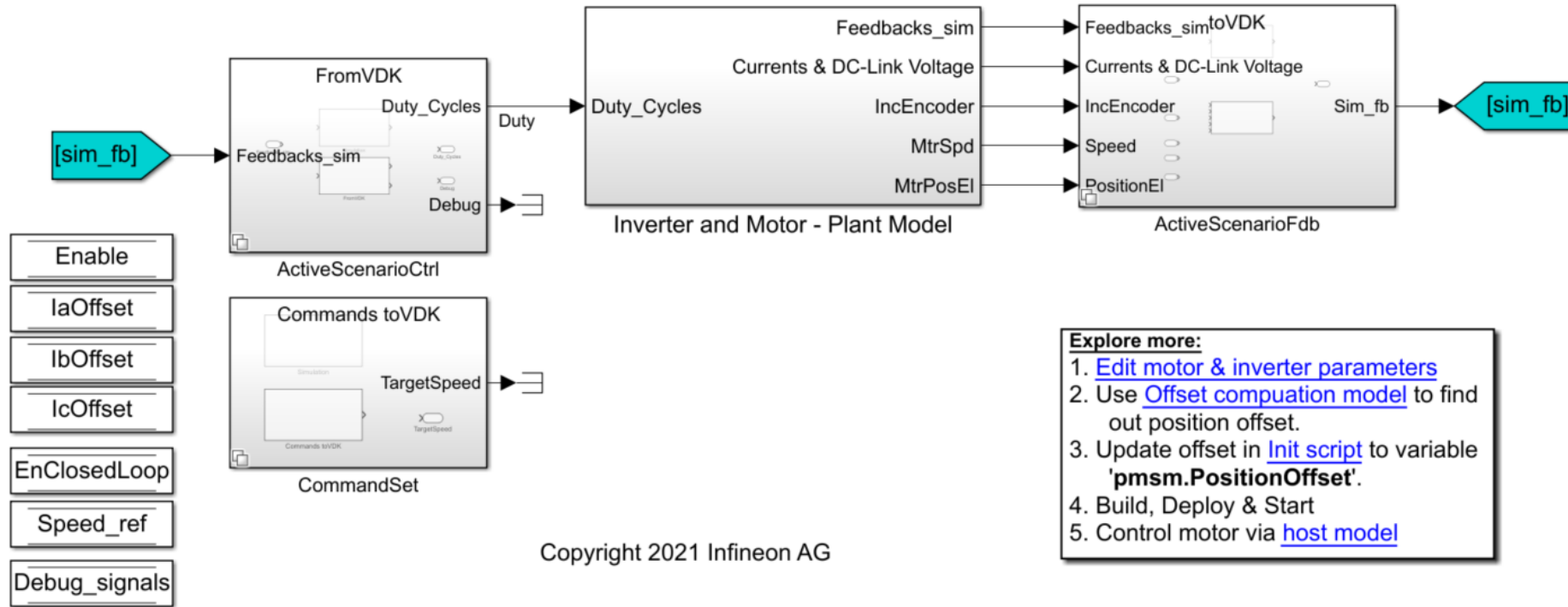

Copyright 2021 Infineon AG

- › Active scenario = 0: Control algorithm executed on AURIX™ TC4x VDK, developed using Infineon Technologies hand-written code
- › Active scenario = 1: Control algorithm executed on Simulink®, developed using MathWorks Motor Control Blockset™ (part of ActiveScenarioCtrl subsystem, MIL)

AURIX™ TC4x Virtual Motor Control Application Kit Plant model in Simulink®



Real inverter and motor

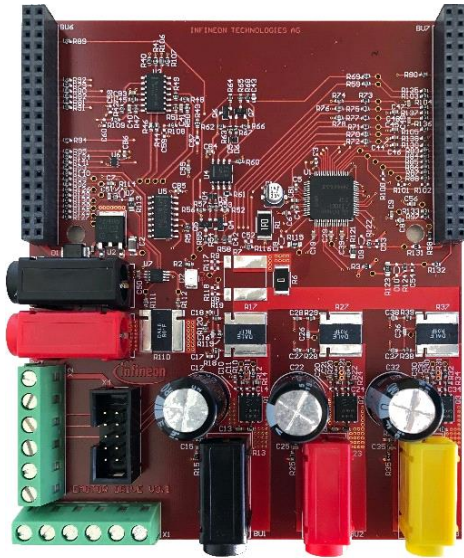

KIT_A2G_TC387_MOTORCTR

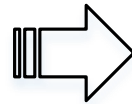

Simple model of inverter, motor and load in Simulink®

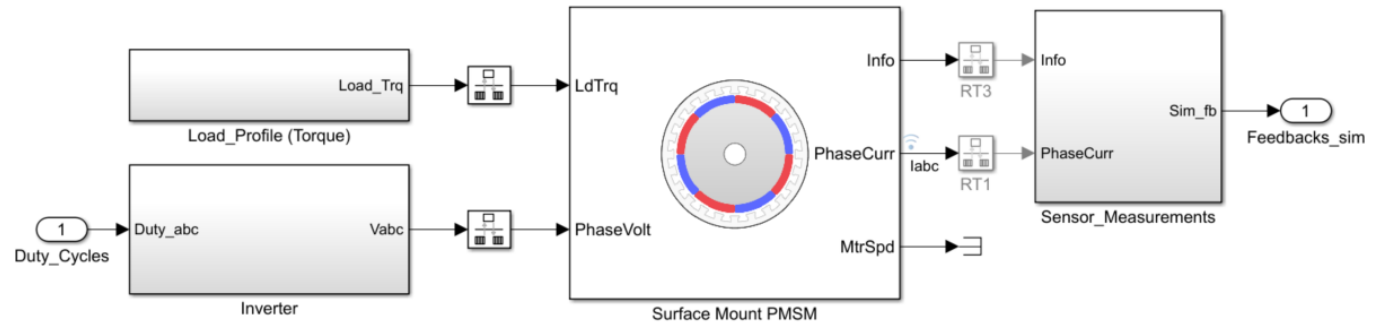

```
%% System Parameters // Hardware parameters
```

```
pmsm = mcb_SetPMSMMotorParameters('DB42S02');  
pmsm.PositionOffset = 0.0;
```

```
%% Parameters below are not mandatory for offset computation
```

```
inverter = mcb_SetInverterParameters('AurixTC3xx_Mctr_PowerBoard_v2');
```

AURIX™ TC4x Virtual Motor Control Application Kit

Synopsys® Virtualizer Blocks in Simulink®



- › General Timer Module (GTM) Timer Output Module (TOM) is used for PWM generation

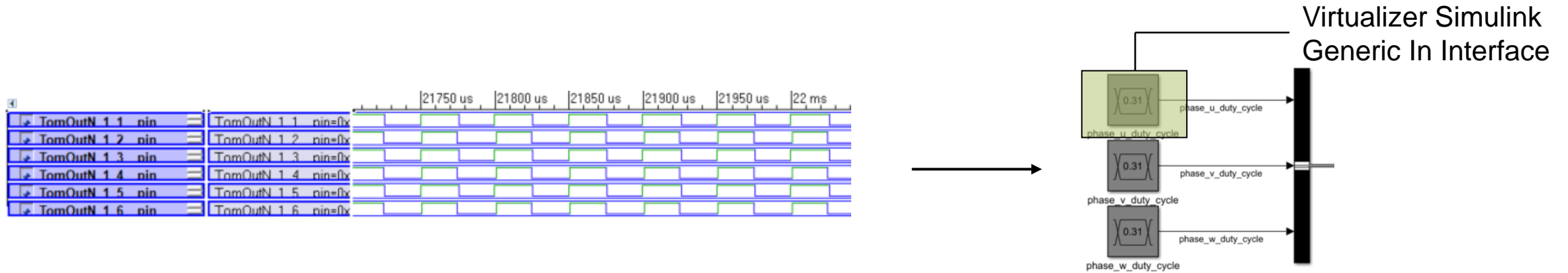

- › General Purpose Timer (GPT12) module is used for incremental encoder support
- › Time-multiplexed analog-to-digital converter (TMADC) is used for phase current sensing

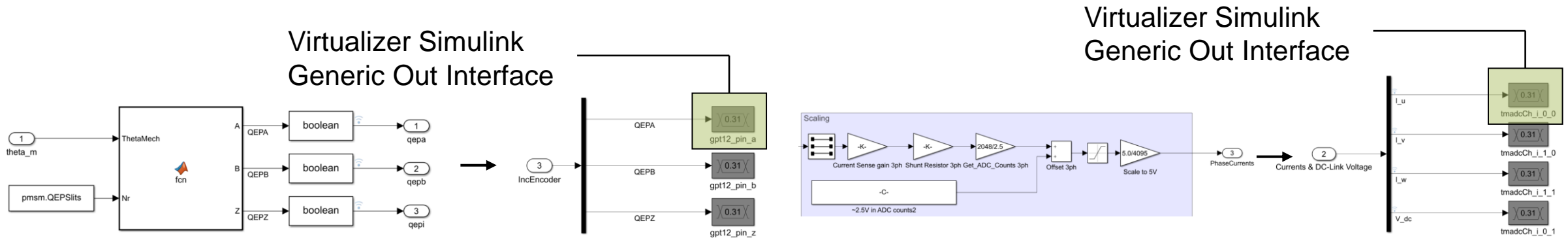

AURIX™ TC4x Virtual Motor Control Application Kit

Run the system simulation



- › To run the system simulation one shall perform following steps:
 1. Open TC4x_MotorControl configuration in VDK
 2. Under TC49x_system/TC49x/Core_System/TriCore0 add .elf path to TriCore0 image
 3. Run VDK_TC499_Simulink_ADC configuration up to initial_crunch
 4. After reaching initial_crunch routine, simulation will be suspended. Click on Resume suspended simulation button in VDK
 5. After VDK simulation reached Running state (indicated in bottom right corner), switch to Simulink window and run Simulink simulation

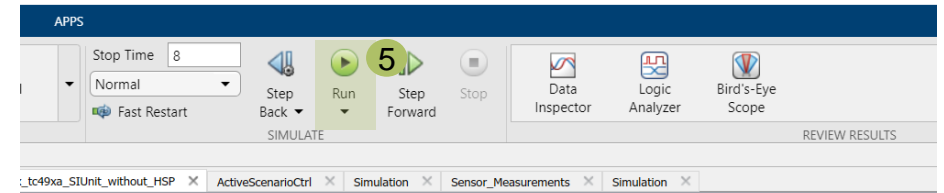
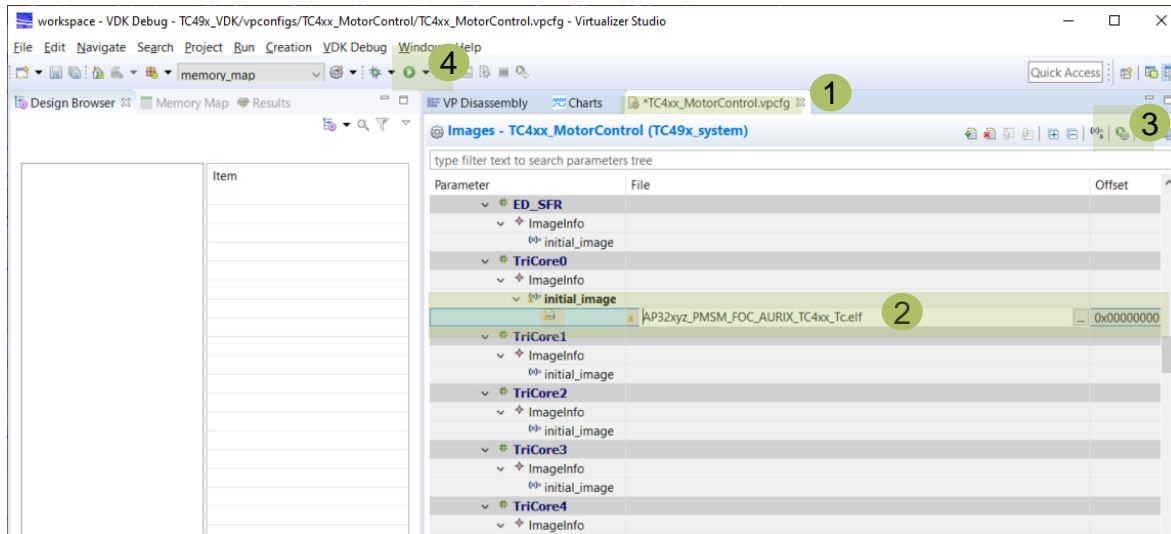

Permanent Magnet Synchronous Motor Field Oriented Control in SI units

Note: This example requires a Infineon AURIX TC4xx Virtual Motor Control Application Kit with PMSM Motor and QEP Sensor

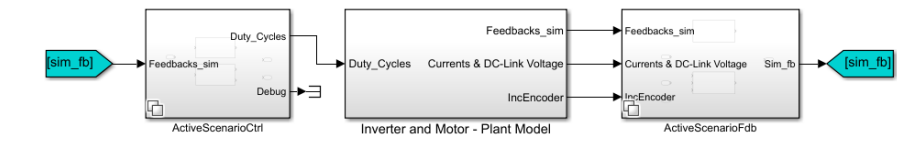

Note: Virtualizer System Interface Library assures that TC49xA VDK time step is synchronized with Simulink® time step.

AURIX™ TC4x Virtual Motor Control Application Kit

Results – Closed loop

- › FOC of PMSM
- › GTM TOM is used for PWM generation
- › Phase currents are measured by using TMADC
- › GPT12 is used for incremental encoder support
- › Maximum speed slew rate: 1000 [rpm/s]

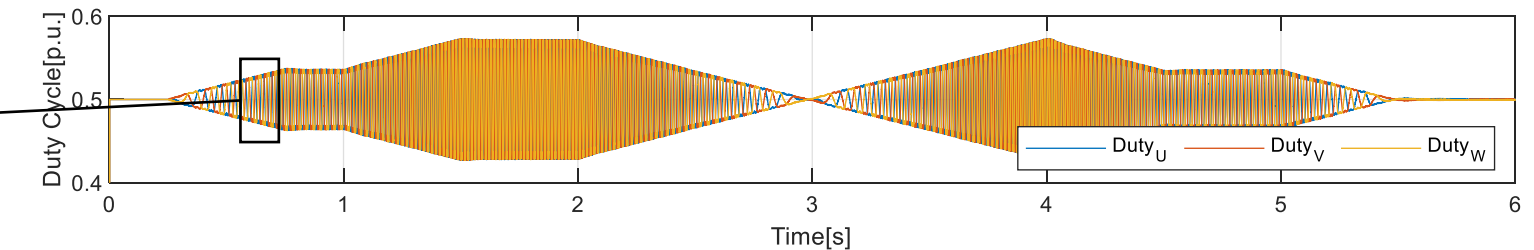
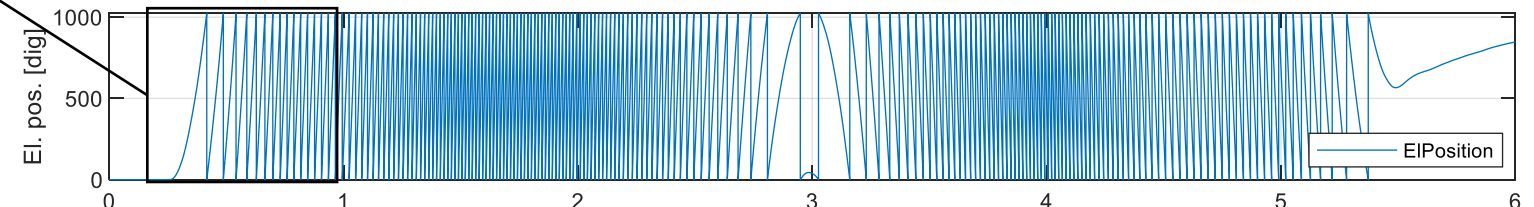
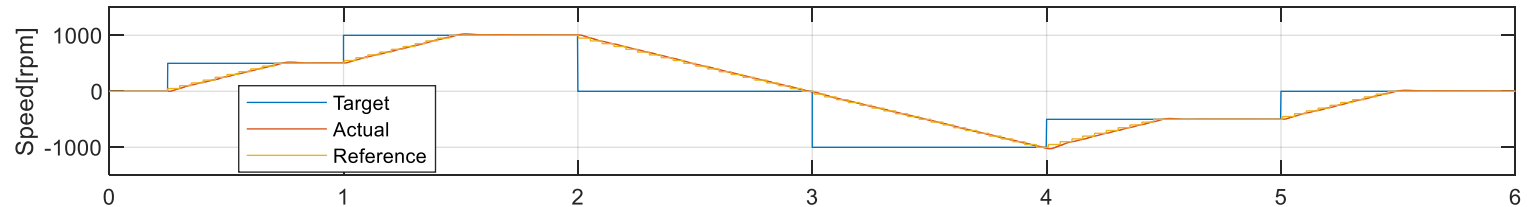
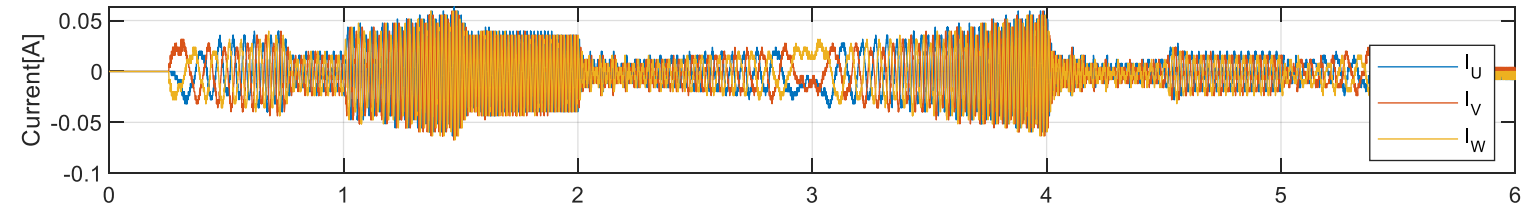
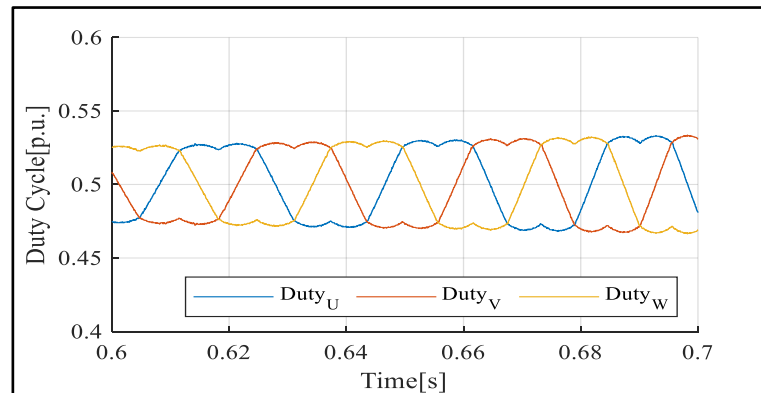
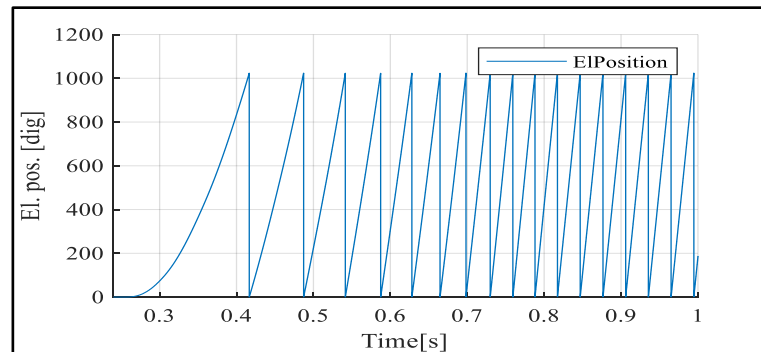

Agenda

1

Objectives

2

AURIX™ TC4x Virtual Prototype

3

AURIX™ TC4x Virtual Motor Control Application Kit

4

Summary

Summary



› Use of AURIX™ Virtual Prototype helps to shorten Time to Market, to save Cost and to improve SW Quality and Safety



› Closed loop co-simulation environment consisting of AURIX™ TC4x Virtual Prototype and Simulink based plant model helped to prepare and validate the motor control SW applications in pre silicon phase



› AURIX™ TC4x Virtual Motor Control Application Kit (combination of AURIX™ TC4x Virtual Prototype, Simulink based plant model and SW) enabled us to demonstrate xEV usecases to our customers and SDK partners

› The MATLAB®/Simulink® embedded coder support package for Infineon Technologies AURIX™ TC4x microcontroller is recently released and helps our customers to speed up prototyping phase

AURIX™ Development Studio

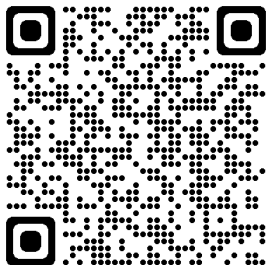

AURIX™ TC4x



Embedded Coder support for AURIX™ TC4x

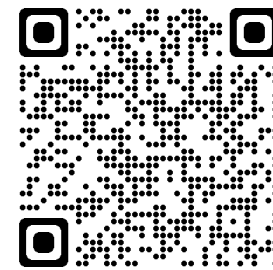

AURIX™ TC4x VDK





Part of your life. Part of tomorrow.